

AUTOMOTIVE CURRENT TRANSDUCER HC6F600-S

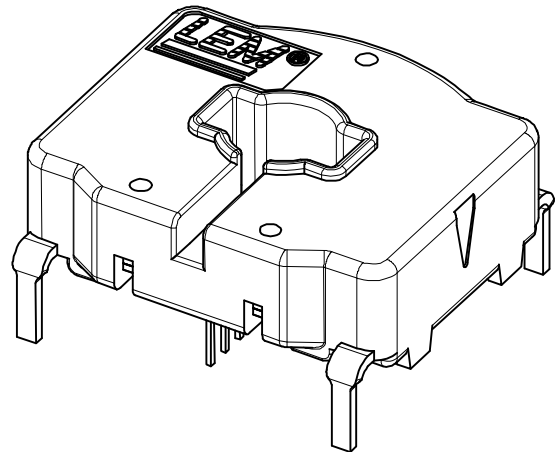
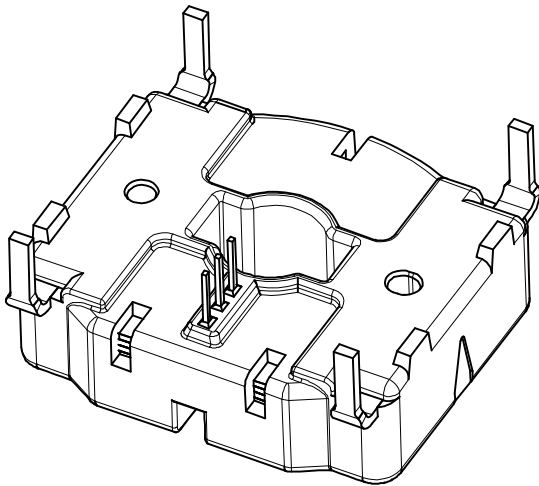

HC6F600-S

Introduction

The HC6F Family is for use on the electronic measurement of DC, AC or pulsed currents in high power and low voltage automotive applications with a galvanic isolation between the primary circuit (high power) and the secondary circuit (electronic circuit).

The HC6F family gives you the choice of having different current measuring ranges in the same housing.

Features

- Open Loop transducer using the Hall effect
- Low voltage application
- Unipolar + 5 V DC power supply
- Primary current measuring range from 200 A up to 800 A
- Maximum rms primary admissible current: defined by busbar the magnetic core or the ASIC to have $T^\circ < + 150^\circ\text{C}$
- Operating temperature range: $- 40^\circ\text{C} < T^\circ < + 125^\circ\text{C}$
- Output voltage: full ratio-metric (in gain and offset)
- Compact design for PCB mounting.

Advantages

- Excellent accuracy
- Very good linearity
- Very low thermal offset drift
- Very low thermal gain drift
- Wide frequency bandwidth
- No insertion losses
- Very good ratio size/current range.

Automotive applications

- Starter Generators
- Converters
- Inverters
- Drives.

Principle of HC6F Family

The open loop transducers use an Hall effect integrated circuit. The magnetic flux density B, contributing to the rise of the Hall voltage, is generated by the primary current I_p to be measured. The current to be measured I_p is supplied by a current source i.e. battery or generator (Fig. 1).

Within the linear region of the hysteresis cycle, B is proportional to:

$$B(I_p) = \text{constant (a)} \times I_p$$

The Hall voltage is thus expressed by:

$$V_H = (R_H/d) \times I_b \times \text{constant (a)} \times I_p$$

Except for I_p , all terms of this equation are constant. Therefore:

$$V_H = \text{constant (b)} \times I_p$$

The measurement signal V_H amplified to supply the user output voltage or current.

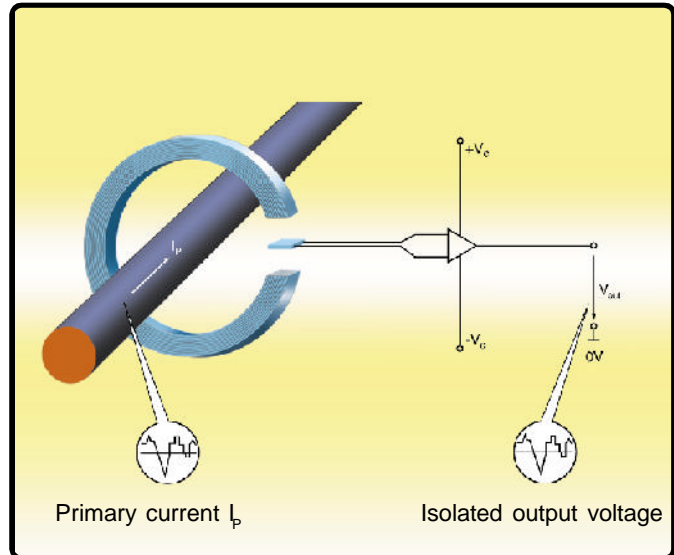

Fig. 1 : Principle of the open loop transducer

HC6F600-S

Dimensions HC6Fxxx-S family (in mm. 1mm = 0.0394 inch)

Secondary connection

| Terminals | Designations |
|-----------|-------------------------|
| 3 | Supply voltage + 5 V DC |
| 1 | V _{OUT} |
| 2 | Ground |
| E1 to E4 | Ground (*) |

(*) Only 1 of these 4 pins could be connected

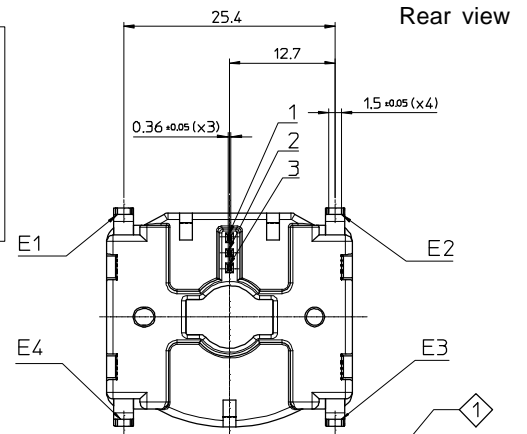
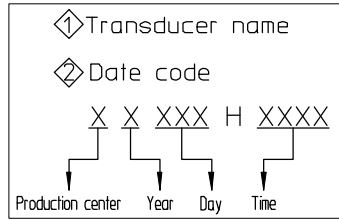

Connection

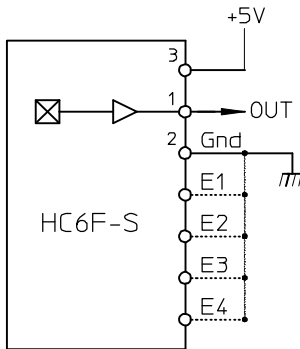

Current flow direction

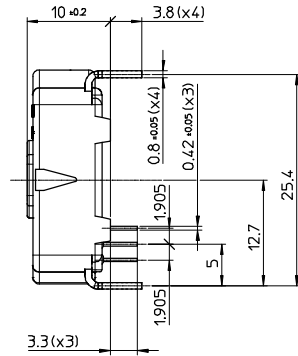

Top view

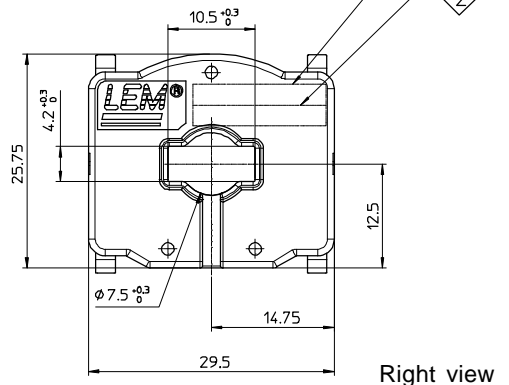

Right view

Bill of materials

- Plastic case
- Magnetic core
- Pins

SPS GF 30
FeSi alloy
Copper alloy tin
plated (lead free)
23 g

Mass

Remarks

- General tolerance ± 0.2 mm
- V_{OUT} > $\frac{V_c}{2}$ when I_p flows in the direction of the arrow.

Electronic schematic

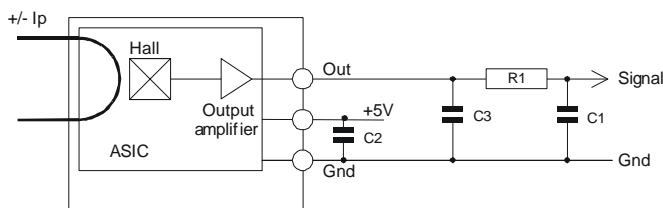

Power supply decoupling capacitor: C2 = 4.7 nF
EMC protection capacitor : C3 = 4.7 nF

Optional:
High frequency signal noise filter:
R1 > 100 Ω
C1 = defined according to the system frequency bandwidth.

HC6F600-S

Absolute maximum ratings (not operating)

| Parameter | Symbol | Unit | Specification | Conditions |
|--|--------------|-------------------|--|--------------|
| Maximum peak primary current (not operating) | $I_{P \max}$ | A | Defined by busbar to have $T^\circ \leq 150^\circ\text{C}$ | |
| Primary nominal DC or current rms | I_{PN} | A | Defined by busbar to have $T^\circ \leq 150^\circ\text{C}$ | |
| Maximum supply voltage (not operating) | $V_{C \max}$ | V | 7 | |
| Secondary maximum admissible power | $P_{S \max}$ | mW | 150 | |
| Ambient operating temperature | T_A | $^\circ\text{C}$ | $-40 < T_A < 125^\circ\text{C}$ | |
| Ambient storage temperature | T_S | $^\circ\text{C}$ | $-40 < T_S < 125^\circ\text{C}$ | |
| Electrostatic discharge voltage | V_{ESD} | V | 2000 | see page 5/5 |
| Maximum admissible vibration | γ | m.s^{-2} | 100 | see page 5/5 |
| Rms voltage for AC isolation test 50 Hz, 1 min | V_d | V | 2000 | |

Operating characteristics

| | Symbol | Unit | Specification | | | Conditions |
|-------------------------------------|----------------------|----------------------------|--|------------|---------|--|
| | | | Min | Typical | Max | |
| Electrical Data | | | | | | |
| Primary current, measuring range | I_{PM} | A | -600 | - | 600 | @ $-40^\circ\text{C} < T^\circ < 125^\circ\text{C}$ |
| Supply voltage ¹⁾ | V_C | V | 4.75 | 5 | 5.25 | @ $-40^\circ\text{C} < T^\circ < 125^\circ\text{C}$ |
| Output voltage (Analog) | V_{OUT} | V | $V_{OUT} = V_C/5 \times (2.5 + 0.0033 \times I_P)$ | | | @ $-40^\circ\text{C} < T^\circ < 125^\circ\text{C}$ |
| Sensitivity | G | V/A | 0.00323 | 0.0033 | 0.00337 | @ $T_A = 25^\circ\text{C}$ |
| Offset voltage | V_O | V | 2.482 | 2.5 | 2.518 | @ $V_C = 5 \text{ V}; T_A = 25^\circ\text{C}; I_P = 0 \text{ A}$ |
| Current consumption | I_C | mA | - | 15 | 20 | @ $-40^\circ\text{C} < T^\circ < 125^\circ\text{C}; 4.75 \text{ V} < V_C < 5.25 \text{ V}$ |
| Load resistance | R_L | $\text{k}\Omega$ | 2 | - | - | |
| Output internal resistance | R_{OUT} | Ω | - | - | 10 | |
| Performance Data | | | | | | |
| Sensitivity error | ϵ_G | % | -2.0 | ± 0.7 | 2.0 | @ $T_A = 25^\circ\text{C}; V_C = 5 \text{ V}; G_{th} = 0.0033$ |
| Electrical offset | I_{OE} | A | -3.0 | ± 1.4 | 3.0 | @ $V_C = 5 \text{ V}; T_A = 25^\circ\text{C}$ |
| | V_{OE} | mV | -10 | ± 4.6 | 10 | |
| Magnetic offset | I_{OM} | A | -2.5 | ± 1.5 | 2.5 | @ After excursion to $\pm I_P; T_A = 25^\circ\text{C}$ |
| | V_{OM} | mV | -8.3 | ± 5.0 | 8.3 | |
| Temperature coefficient of | TCI_{OE} | $\text{mA}/^\circ\text{C}$ | -42.4 | ± 18.2 | 42.4 | @ $-40^\circ\text{C} < T^\circ < 125^\circ\text{C}; V_C = 5 \text{ V}$ |
| | TCV_{OE} | $\text{mV}/^\circ\text{C}$ | -0.14 | ± 0.06 | 0.14 | |
| Temperature coefficient of G | TCG | $\%/^\circ\text{C}$ | -0.04 | ± 0.02 | 0.04 | @ $-40^\circ\text{C} < T^\circ < 125^\circ\text{C}; V_C = 5 \text{ V}$ |
| Linearity error | ϵ_L | $\% I_P$ | -1.0 | ± 0.5 | 1.0 | @ $I_P; V_C = 5 \text{ V}; T_A = 25^\circ\text{C}$ |
| Response time | t_r | μs | - | 8 | 15 | @ $di/dt = 50 \text{ A}/\mu\text{s}; I_T = 100 \text{ A}$ |
| Frequency bandwidth ²⁾ | BW | kHz | 20 | - | - | @ -3 dB; $I_T = 40 \text{ A rms}$ |
| Output voltage noise peak-peak | $V_{no \text{ p-p}}$ | mV | - | 10 | 15 | @ $T_A = 25^\circ\text{C}; 0 \text{ Hz} < f < 1 \text{ MHz}$ |
| Output voltage noise rms | $V_{no \text{ rms}}$ | mV | - | 2.5 | 3.5 | @ $T_A = 25^\circ\text{C}; 0 \text{ Hz} < f < 1 \text{ MHz}$ |

Notes: ¹⁾ The output voltage V_{OUT} is fully ratio-metric and depends on the supply voltage V_C .
The V_C value must be measured and used with the following formula:

$$I_P = \left(V_{OUT} - \frac{V_C}{2} \right) \times \frac{1}{G} \times \frac{5}{V_C} \quad \text{with } G \text{ in } (V/A)$$

²⁾ Small signal only to avoid excessives heatings of the busbar, the magnetic core and the ASIC.

HC6F600-S

PERFORMANCE PARAMETERS DEFINITIONS

Sensitivity:

The Transducer's sensitivity **G** is the slope of the straight line $V_{OUT} = f(I_p)$, it must establish the relation:
 $V_{OUT}(I_p) = V_C/5 (G \times I_p + 2.5)$ (*)

(*) For all symetrics transducers.

Offset voltage :

Is the output voltage when the primary current is null. The ideal value of V_o is $V_C/2$. So, the difference of $V_o - V_C/2$ is called the total offset voltage error. This offset error can be attributed to the electrical offset (due to the resolution of the ASIC quiescent voltage trimming), the magnetic offset, the thermal drift and the thermal hysteresis.

Magnetic offset:

The magnetic offset is the consequence of an over-current on the primary side. It's defined after an excursion of I_p max.

Linearity:

Is the maximum positive or negative discrepancy with a reference straight line $V_{OUT} = f(I_p)$.
 Unit: linearity (%) expressed with full scale of I_p max.

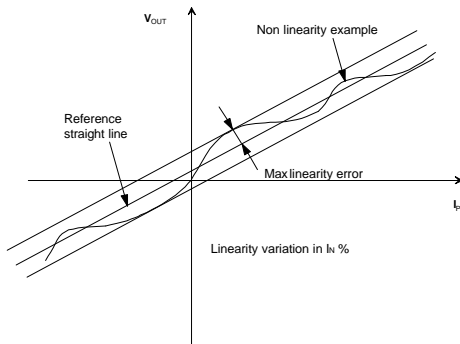

Response time (delay time) t_r :

Is the time between the primary current signal and the output signal reach at 90 % of its final value.

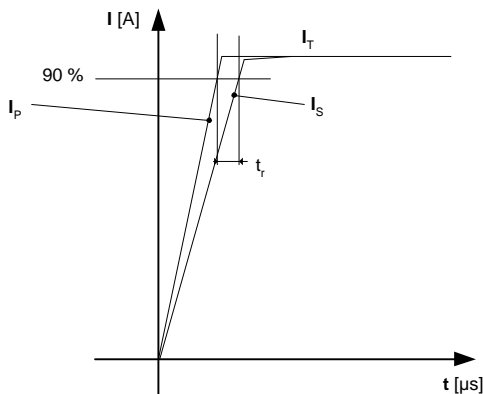

Output noise voltage:

The output voltage noise is the result of the noise floor of the Hall elements and the linear I_C amplifier sensitivity.

Offset drift:

The error of the offset in the operating temperature ϵ_{Offset} is the relative variation of the offset in the temperature considered with the initial offset at 25°C. The offset temperature coefficient $TCV_{OE} (TCI_{OE})$ in the operating temperature is the slope off $\epsilon_{Offset} = f(T)$.

Sensitivity drift:

The error of the sensitivity in the operating temperature sensitivity Error is the relative variation of the sensitivity in the temperature considered with the initial sensitivity at 25°C. Sensitivity temperature coefficient **TCG**.

Typical:

Theoretical value or usual accuracy recorded during the production.

Environmental test specifications

| Name | Standard | Conditions |
|---|---------------------|--|
| Thermal shocks | IEC 60068 Part 2-14 | T° - 40°C to 125°C / 1000 cycles not connected |
| Low T° operation at min supply voltage | IEC 60068 Part 2-1 | T° - 40°C / 1000 H supply voltage = 4.75 V |
| High T° operation at max supply voltage | IEC 60068 Part 2-2 | T° 125°C / 1000 H supply voltage = 5.25 V |
| Temperature humidity bias | IEC 60068 Part 2-3 | T° 90°C / 95 % RH/ 1000 H supply voltage = 5.25 V |
| Mechanical Tests | | |
| Vibration | IEC 60068 Part 2-64 | Room T°, acceleration 100 m/s ² , frequency 20 to 500 Hz/96 H each axis |
| Drop test | IEC 60068 Part 2-29 | Height 750 mm concrete floor each directions |
| EMC Test | | |
| Electrostatic discharge | JESD22-A114-B | Applied voltage = ± 2 kV pin to pin number of discharge = 1 |