

# AUTOMOTIVE CURRENT SENSOR HC6F500-S

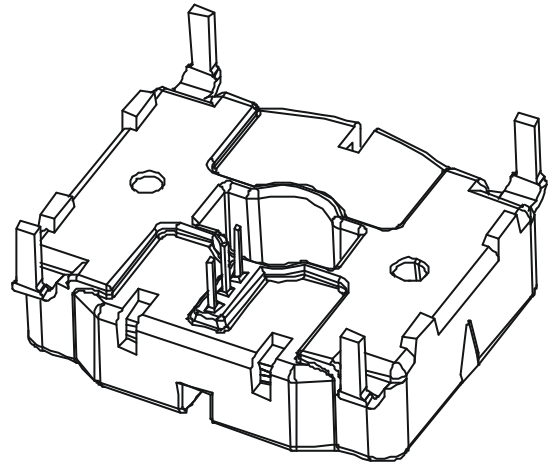
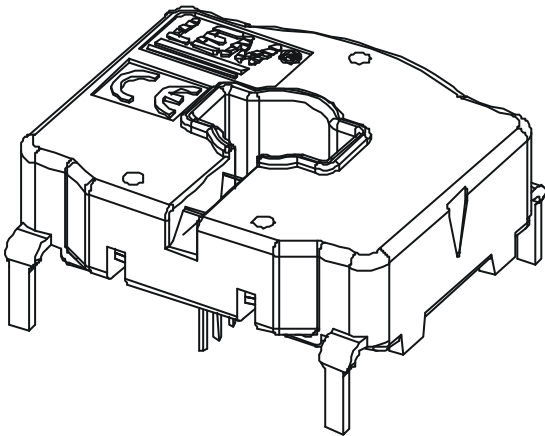

# HC6F500-S Datasheet

## Introduction

The HC6F Family is for use on the electronic measurement of DC, AC or pulsed currents in high power and low voltage automotive applications with a galvanic isolation between the primary circuit (high power) and the secondary circuit (electronic circuit).

The HC6F family gives you the choice of having different current measuring ranges in the same housing.

## Features

- Open Loop transducer using the Hall effect
- Low voltage application
- Unipolar + 5 V DC power supply
- Primary current measuring range from 200 A up to 800 A
- Maximum rms primary admissible current: defined by busbar to have  $T^{\circ} < + 150^{\circ}\text{C}$
- Operating temperature range:  $- 40^{\circ}\text{C} < T^{\circ} < + 125^{\circ}\text{C}$
- Output voltage: full ratio-metric (in gain and offset)
- Compact design for PCB mounting.

## Advantages

- Excellent accuracy
- Very good linearity
- Very low thermal offset drift
- Very low thermal gain drift
- Wide frequency bandwidth
- Noinsertion losses
- Very good ratio size/current range

## Automotive applications

- Starter Generators
- Converters
- Inverters
- Drives.

## Principle of HC6F Family

The open loop transducers use an Hall effect integrated circuit. The magnetic induction  $B$ , contributing to the rise of the Hall voltage, is generated by the primary current  $I_p$  to be measured. The control current  $I_c$  is supplied by a current source i.e. battery or generator (Fig. 1).

Within the linear region of the hysteresis cycle,  $B$  is proportional to:

$$I_p(B) = \text{constant}(a) \times I_p$$

The Hall voltage is thus expressed by:

$$V_H = (K/d) \times l \times \text{constant}(a) \times I_p$$

Except for  $I_p$ , all terms of this equation are constant. Therefore:

$$V_H = \text{constant}(b) \times I_p$$

The measurement signal  $V_H$  amplified to supply the user output voltage or current.

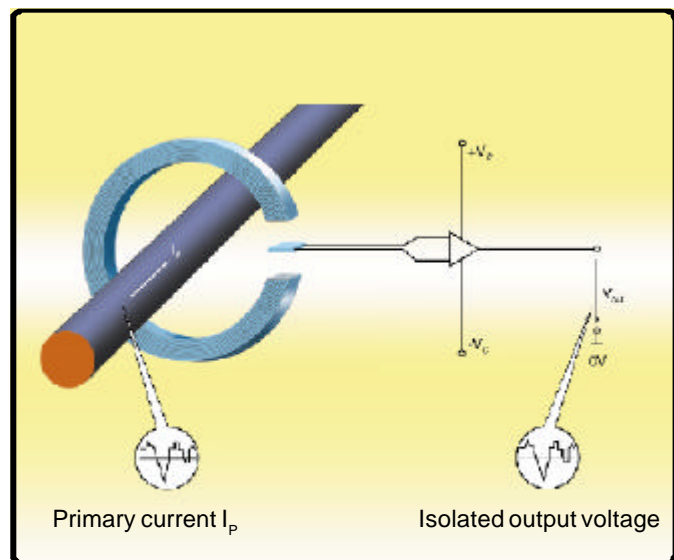

Fig. 1: Principle of the open loop transducer

# HC6F500-S Datasheet

Dimensions HC6Fxxx-S family (in mm. 1mm = 0.0394 inch)

## Secondary connection

Terminals	Designations
3	Supply voltage + 5 V DC
1	$V_{out}$
2	Ground
E1 to E4	Ground (*)

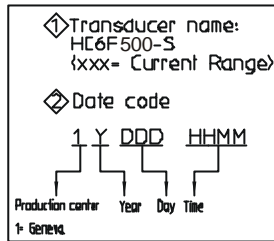

(\*) Only 1 of these 4 pins could be connected

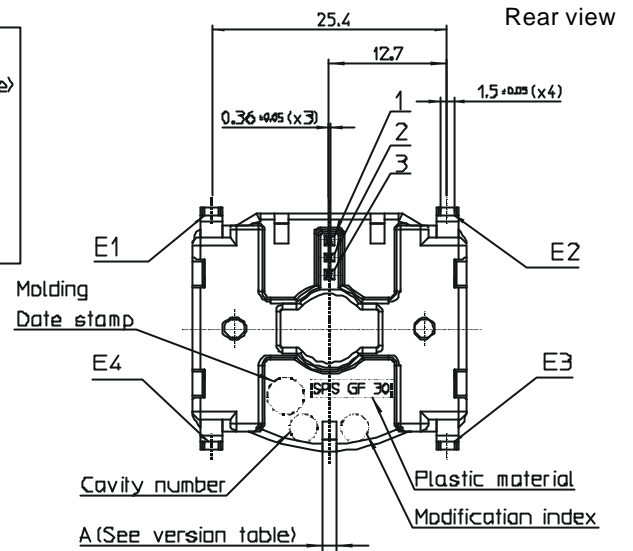

## Connection

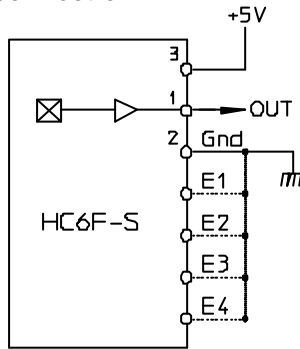

Current flow direction

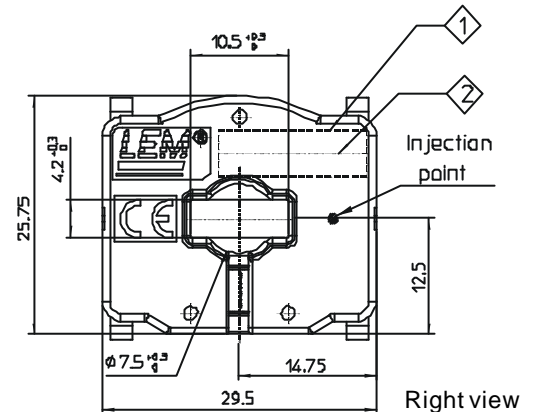
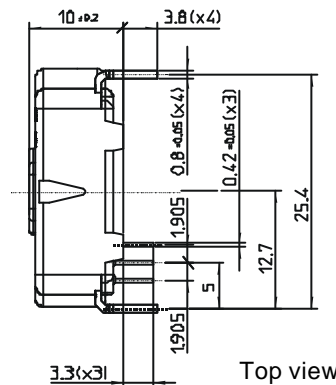

## Bill of materials

- Plastic case
- Magnetic core
- Pins

SPS GF 30  
FeSi alloy  
Copper alloy tin plated (lead free)  
23 g

## Remarks

- General tolerance  $\pm 0.2$  mm
- $V_{OUT} > \frac{V_c}{2}$  when  $I_p$  flows in the direction of the arrow.

## Mass

## Electronic schematic

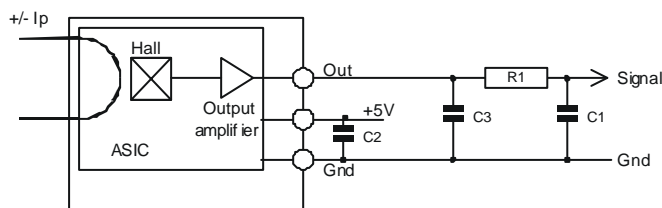

Power supply decoupling capacitor: C2 = 47 nF  
EMC protection capacitor : C3 = 4.7 nF

Optional:  
High frequency signal noise filter:  
R1 > 100 ohms  
C1 = defined according to the system frequency bandwidth

# HC6F500-S Datasheet

## Absolute maximum ratings (not operating)

Parameter	Symbol	Unit	Specification	Conitions
Maximum peak primary current (not operating)	$I_{P\ maxi}$	A	Defined by busbar to have $T^\circ \leq 150^\circ\text{C}$	
Primary nominal DC or rms current	$I_{PN}$	A	Defined by busbar to have $T^\circ \leq 150^\circ\text{C}$	
Maximum supply voltage (not operating)	$V_{C\ maxi}$	V	7	
Secondary maximum admissible power	$PS\ maxi$	mW	150	
Ambient operating temperature	$T_A$	$^\circ\text{C}$	$-40 < T_A < 125^\circ\text{C}$	
Ambient storage temperature	$T_S$	$^\circ\text{C}$	$-40 < T_S < 125^\circ\text{C}$	
Electrostatic discharge voltage	$V_{ESD}$	V	2000	JESD22-A114-B
Maximum admissible vibration	$\gamma$	$\text{m.s}^{-2}$	100	IEC60068-2-64
Rms voltage for AC isolation test	$V_d$	V	2000	IEC 60664-1

## Operating characteristics

	Symbol	Unit	Specification			Conditions
			Mini	Typical	Maxi	
<b>Electrical Data</b>						
Primary current, measuring range	$I_{PM}$	A	-500	-	500	@ $-40^\circ\text{C} < T^\circ < 125^\circ\text{C}$
Supply voltage <sup>1)</sup>	$V_C$	V	4.75	5.00	5.25	@ $-40^\circ\text{C} < T^\circ < 125^\circ\text{C}$
Output voltage( Analog) <sup>1)</sup>	$V_{out}$	V	$V_{OUT} = V_C/5 \cdot (2.5 + 0.004 \cdot I)$			@ $-40^\circ\text{C} < T^\circ < 125^\circ\text{C}$
Sensitivity	$G$	V/A	0.00392	0.004	0.00408	@ $T_A = 25^\circ\text{C}$
Offset voltage	$V_O$	V	2.482	2.5	2.518	@ $V_C = 5\text{ V}; T_A = 25^\circ\text{C}; I_P = 0\text{ A}$
Current consumption	$I_C$	mA	-	15	20	@ $-40^\circ\text{C} < T^\circ < 125^\circ\text{C}; 4.75\text{ V} < V_C < 5.25\text{ V}$
Load resistance	$R_L$	$\text{K}\Omega$	2	-	-	
Output internal resistance	$R_{OUT}$	$\Omega$	-	-	10	
<b>Performance Data</b>						
Sensitivity error <sup>1)</sup>	$e_G$	%	-2.0	$\pm 0.7$	2.0	@ $T_A = 25^\circ\text{C}, V_C = 5\text{ V}; G_{th} = 0.004\text{ V/A}$
Electrical offset current	$I_{OE}$	A	-2.5	$\pm 1.1$	2.5	@ $V_C = 5\text{ V}; T_A = 25^\circ\text{C}$
	$V_{OE}$	mV	-10	$\pm 4.4$	10	
Magnetic offset current	$I_{OM}$	A	-2.5	$\pm 1.5$	2.5	@ After excursion to $\pm I_P; T_A = 25^\circ\text{C}$
	$V_{OM}$	mV	-10	$\pm 6$	10	
Temperature coefficient of	$TCI_{OE}$	$\text{mA}/^\circ\text{C}$	-35	$\pm 15$	35	@ $-40^\circ\text{C} < T^\circ < 125^\circ\text{C}; V_C = 5\text{ V}$
	$TCV_{OE}$	$\text{mV}/^\circ\text{C}$	-0.14	$\pm 0.06$	0.14	
Temperature coefficient of $G$	$TCG$	$\%/^\circ\text{C}$	-0.04	$\pm 0.02$	0.04	@ $-40^\circ\text{C} < T^\circ < 125^\circ\text{C}; V_C = 5\text{ V}$
Linearity error	$\epsilon_L$	$\% I_P$	-1.0	$\pm 0.5$	1.0	@ $I_P; V_C = 5.00\text{ V}, T_A = 25^\circ\text{C}$
Response time	$t_r$	$\mu\text{s}$	-	8	15	@ $di/dt = 50\text{ A}/\mu\text{s}; I_T = 400\text{ A}$
Frequency bandwidth <sup>2)</sup>	$BW$	kHz	20	-	-	@ -3 dB
Output voltage noise peak-peak	$V_{no\ p-p}$	mV	-	8	12	@ $T_A = 25^\circ\text{C}; 0\text{ Hz} < f < 1\text{ MHz}$
Output voltage noise rms	$V_{no\ rms}$	mV	-	2.5	3.5	@ $T_A = 25^\circ\text{C}; 0\text{ Hz} < f < 1\text{ MHz}$

**Notes:** <sup>1)</sup> The output voltage  $V_{OUT}$  is fully ratio-metric and depends on the supply voltage  $V_C$ .  
The  $V_C$  value must be measured and used with the following formula:

$$I_P = \left( V_{out} - \frac{V_C}{2} \right) \times \frac{1}{G} \times \frac{5}{V_C} \quad \text{With } G \text{ in (V/A)}$$

<sup>2)</sup> Small signal only to avoid excessive heatings of the magnetic core.

# HC6F500-S Datasheet

## PERFORMANCE PARAMETERS DEFINITIONS

### Sensitivity:

The Transducer's sensitivity  $G$  is the slope of the straight line

$V_{out} = f(I_p)$ , it must establish the relation:

$$V_{out}(I_p) = V_C/5 (G \times I_p + 2.5) (*)$$

\* For all symetrics transducers

### Offset voltage:

Is the output voltage when the primary current is null. The ideal value of  $V_o$  is  $V_C/2$ . So, the difference of  $V_o - V_C/2$  is called the total offset voltage error. This offset error can be attributed to the electrical offset (due to the resolution of the ASIC quiescent voltage trimming), the magnetic offset, the thermal drift and the thermal hysteresis.

### Magnetic offset:

The magnetic offset is the consequence of an over-current on the primary side. It's defined after an excursion of  $I_{P\ maxi}$ .

### Linearity:

Is the maximum positive or negative discrepancy with a reference straight line  $V_{OUT} = f(I_p)$ .

Unit: linearity (%) expressed with full scale of  $I_{P\ maxi}$ .

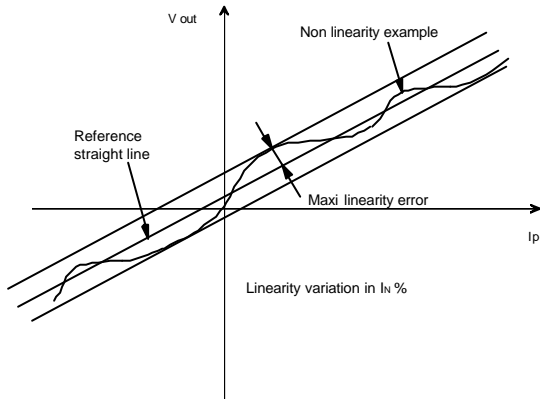

### Response time (delay time) $t_r$ :

Is the time between the primary current signal and the output signal reach at 90 % of its final value

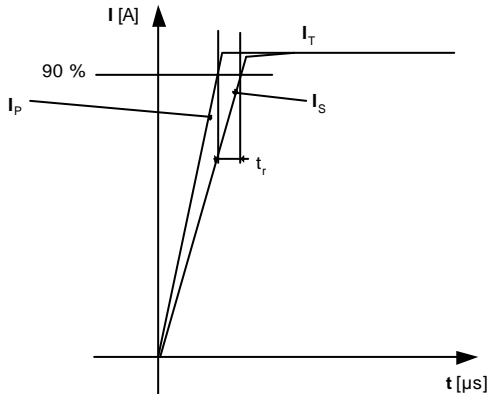

### Output noise voltage:

The output voltage noise is the result of the noise floor of the Hall elements and the linear  $I_C$  amplifier sensitivity.

### Offset drift:

The error of the offset in the operating temperature  $\epsilon_{Offset}$  is the relative variation of the offset in the temperature considered with the initial offset at 25°C. The offset temperature coefficient  $TCV_{OE}$  ( $TCI_{OE}$ ) in the operating temperature is the slope off  $\epsilon_{Offset} = f(T)$ .

### Sensitivity drift:

The error of the sensitivity in the operating temperature Sensitivity Error is the relative variation of the sensitivity in the temperature considered with the initial sensitivity at 25°C. Sensitivity temperature coefficient  $TC\epsilon_G$ .

### Typical:

Theoretical value or usual accuracy recorded during the production.

### Environmental test specifications

Name	Standard	Conditions
Thermal shocks	IEC 60068 Part 2-14	T° - 40°C to 125°C / 1000 cycles not connected
Low T° operation at mini supply voltage	IEC 60068 Part 2-1	T° - 40°C / 1000 H supply voltage = 4.75 V
High T° operation at maxi supply voltage	IEC 60068 Part 2-2	T° 125°C / 1000 H supply voltage = 5.25 V
Temperature humidity bias	IEC 60068 Part 2-3	T° 85°C / 85 % RH/ 1000 H
<b>Mechanical Tests</b>		
Vibration	IEC 60068 Part 2-64	see note (2) page 4
Drop test	IEC 60068 Part 2-29	Height 750 mm concrete floor each directions
<b>EMC Test</b>		
Electrostatic discharge	JESD22-A114-B	Applied voltage = ± 2 kV pin to pin number of discharge = 1
Rms voltage for AC isolation test	IEC 60664 Part 1	2 kV, 50 Hz, 1 min
Bulk current injected-radiated immunity	ISO 11452 Part 4	