

# AUTOMOTIVE CURRENT TRANSDUCER OPEN LOOP TECHNOLOGY

## HAH1DR 400-S/SP1

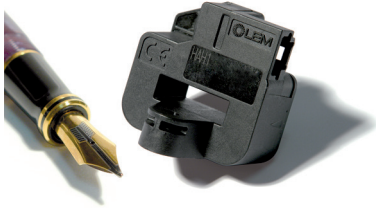

RoHS

### Introduction

The HAH1DR family is for the electronic measurement of DC, AC or pulsed currents in high power automotive applications with galvanic separation between the primary circuit (high power) and the secondary circuit (electronic circuit).

The HAH1DR family gives you the choice of having different current measuring ranges in the same housing (from  $\pm 200$  A up to  $\pm 900$  A).

### Features

- Open Loop transducer using the Hall effect
- Unipolar + 5 V DC power supply
- Primary current measuring range  $\pm 400$  A
- Maximum RMS primary admissible current: defined by busbar to have  $T^\circ < + 150$  °C
- Operating temperature range:  $- 40$  °C  $< T^\circ < + 125$  °C
- Output voltage: full ratio-metric (in sensitivity and offset)
- Compact design.

### Advantages

- Excellent accuracy
- Very good linearity
- Very low thermal offset drift
- Very low thermal sensitivity drift
- Wide frequency bandwidth
- No insertion losses.

### Automotive applications

- Battery monitoring
- Starter Generators
- Inverters
- HEV application
- EV application.

### Principle of HAH1DR Family

The open loop transducers uses a Hall effect integrated circuit. The magnetic flux density  $B$ , contributing to the rise of the Hall voltage, is generated by the primary current  $I_p$  to be measured. The current to be measured  $I_p$  is supplied by a current source i.e. battery or generator (Figure 1).

Within the linear region of the hysteresis cycle,  $B$  is proportional to:

$$B(I_p) = \text{constant}(a) \times I_p$$

The Hall voltage is thus expressed by:

$$V_H = (R_H/d) \times I \times \text{constant}(a) \times I_p$$

Except for  $I_p$ , all terms of this equation are constant. Therefore:

$$V_H = \text{constant}(b) \times I_p$$

The measurement signal  $V_H$  amplified to supply the user output voltage or current.

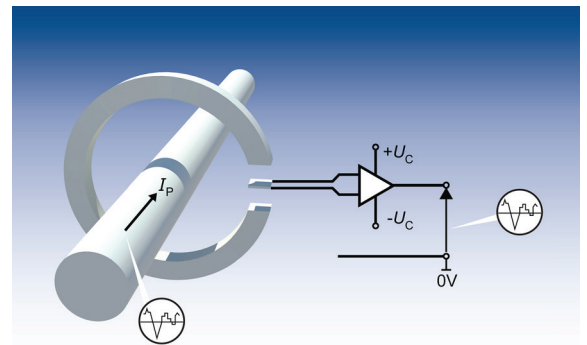
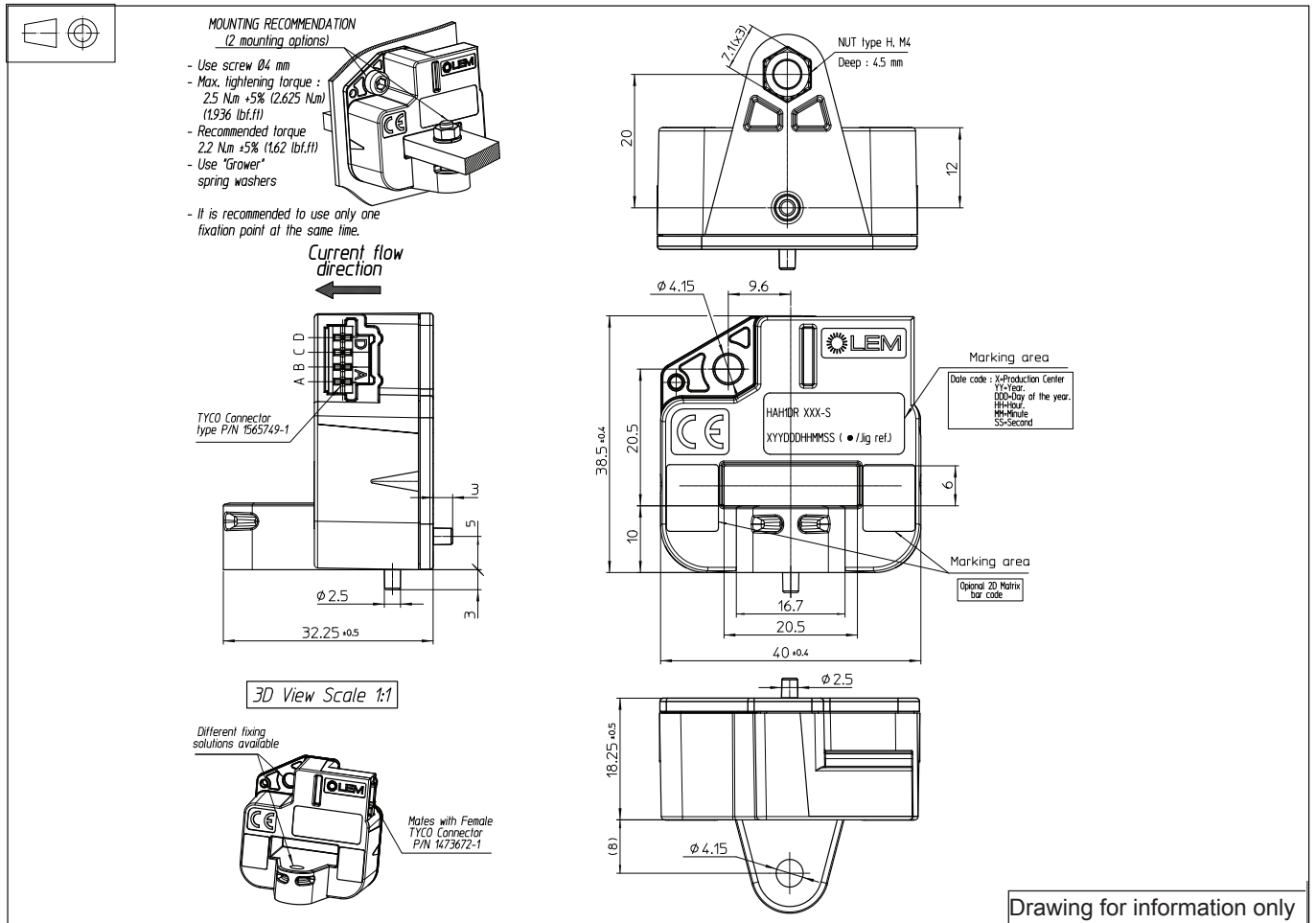

Fig. 1: Principle of the open loop transducer

## Dimensions HAH1DR 400-S/SP1 (in mm)



### Mechanical characteristics

- Plastic case PBT GF 30
- Magnetic core Iron silicon alloy
- Mass 38 g
- Electrical terminal coating Brass gold plated

### Mounting recommendation

- Connector type TYCO 1473672-1

### Electronic schematic

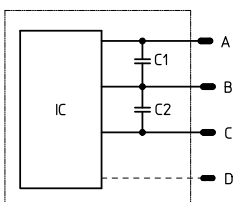

Components list		DR version
IC	Hall sensor ASIC	
C1	Decoupling capacitor	4.7 nF
C2	Decoupling capacitor	47 nF

Pin out	
A	$V_{out}$
B	Ground
C	$U_c$ (5V)
D	Not connected

### Remarks

- $V_{out} > 2.5$  when  $I_p$  flows in the direction of the arrow.

### System architecture (example)

$C_L \leq 100$  nF EMC protection

RC Low pass filter EMC protection (optional)

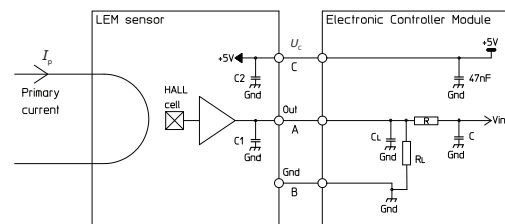

### Diagnostic Mode

$R_L > 10$  k $\Omega$  optional resistor for signal line diagnostic

$V_{out}$	Diagnostic
Open circuit	$V_{in} = < 0.15V$
Short GND	$V_{in} = < 0.15V$

## HAH1DR 400-S/SP1

### Absolute Maximum ratings (not operating)

Parameter	Symbol	Unit	Specification			Conditions
			Min	Typical	Max	
Primary current peak	$\hat{I}_{Pmax}$				1)	
Supply continuous over voltage	$U_C$	V			7	Not operating
Reverse voltage 2)			- 0.5			1 min @ $T_A = 25\text{ °C}$
Ambient storage temperature	$T_S$	°C	- 55		125	
Electrostatic discharge voltage	$U_{ESD}$	kV			2	JESD 22-A114-B (HBM)
Continuous output current	$I_{out}$	mA	- 10		10	
RMS voltage for AC insulation test, 50 Hz, 1 min	$U_d$	kV			2	50 Hz, 1 min
Continuous output over voltage (Analog)	$V_{out}$	V	- 0.5		$U_C + 0.5$	
Insulation resistance	$R_{IS}$	MΩ	500			500 V - ISO 16750-2
Output Short circuit duration	$t_c$	minutes			2	

### Operating characteristics in nominal range ( $I_{PN}$ )

Parameter	Symbol	Unit	Specification			Conditions
			Min	Typical	Max	
<b>Electrical Data</b>						
Primary current	$I_{PN}$	A	- 400		400	
Supply voltage	$U_C$	V	4.75	5	5.25	
Ambient operating temperature	$T_A$	°C	- 40		125	Connector limited 105 °C
Output voltage (Analog) 3)	$V_{out}$	V	$V_{out} = (U_C/5) \cdot (V_o + G \cdot I_p)$			@ $U_C$
Sensitivity 3)	$G$	mV/A		5		@ $U_C = 5\text{ V}$
Current consumption	$I_C$	mA		15	20	@ $U_C = 5\text{ V}$ , - 40 °C < $T_A$ < 125 °C
Load resistance	$R_L$	KΩ	10			
Capacitive loading	$C_L$	nF	1		100	
Output internal resistance	$R_{out}$	Ω			10	DC to 1 kHz
Ratiometricity error	$\epsilon_r$	%		0.5		
<b>Performance data</b>						
Sensitivity error	$\epsilon_G$	%	- 1	± 0.5	1	@ $T_A = 25\text{ °C}$ , @ $I = I_p$
Electrical offset current	$I_{OE}$	A		± 0.8		@ $T_A = 25\text{ °C}$ , @ $U_C = 5\text{ V}$
Magnetic offset current	$I_{OM}$			± 1		@ $T_A = 25\text{ °C}$ , @ $U_C = 5\text{ V}$ , after ± $I_p$
Global offset current	$I_O$		- 2.2		2.2	@ $T_A = 25\text{ °C}$
Average temperature coefficient of $V_{OE}$	$TCI_{OEAV}$	mV/°C	- 0.08	± 0.03	0.08	@ - 40 °C < $T_A$ < 125 °C
Average temperature coefficient of $G$	$TCG_{AV}$	%/°C	- 0.035	± 0.02	0.035	@ - 40 °C < $T_A$ < 125 °C
Linearity error	$\epsilon_L$	%	- 1		1	@ $U_C = 5\text{ V}$ , @ $T_A = 25\text{ °C}$ , @ $I = I_p$
Step response time to 90 % $I_{PN}$	$t_t$	µs		6	10	@ $di/dt = 100\text{ A/µs}$
Frequency bandwidth 4)	$BW$	kHz		30		@ - 3 dB
Output clamping voltage minimum	$V_{SZ}$	V			0.1	@ $U_C = 5\text{ V}$ , @ $T_A = 25\text{ °C}$
Output clamping voltage maximum			4.9		@ $U_C = 5\text{ V}$ , @ $T_A = 25\text{ °C}$	
Output voltage noise peak-peak	$V_{no\ p-p}$	mV			20	DC to 1 kHz

- Notes:**
- 1) Busbar temperature must be below 150 °C
  - 2) Transducer not protected against reverse polarity
  - 3) The output voltage  $V_{out}$  is fully ratiometric: The offset and sensitivity are dependent on the supply voltage  $U_C$  relative to the following formula:

$$I_p = \left( \frac{5}{U_C} \cdot V_{out} - V_o \right) \cdot \frac{1}{G} \text{ with } G \text{ in (V/A)}$$

- 4) Tested only with small signal only to avoid excessive heating of the magnetic core.

# HAH1DR 400-S/SP1

HAH1DR 400-S/SP1 Sensitivity error (%)

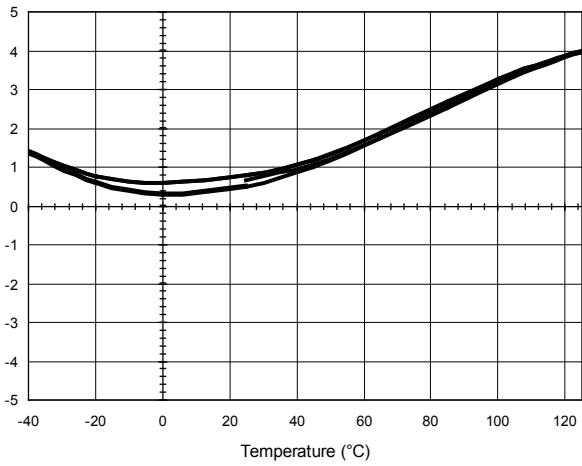

HAH1DR 400-S/SP1 Electrical offset error (A)

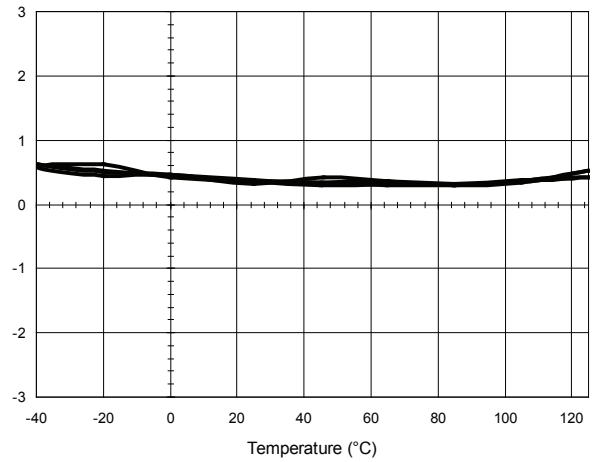

HAH1DR 400-S/SP1 Frequency bandwidth

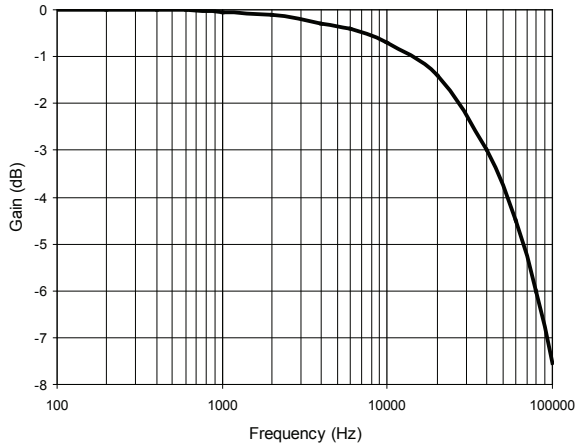

HAH1DR 400-S/SP1 Phase

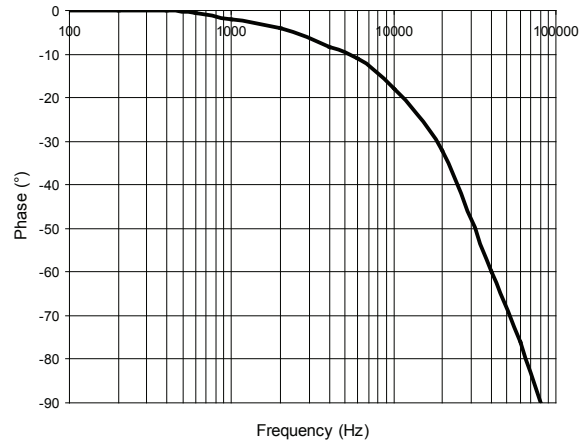

Typical response time at 100 A/μs

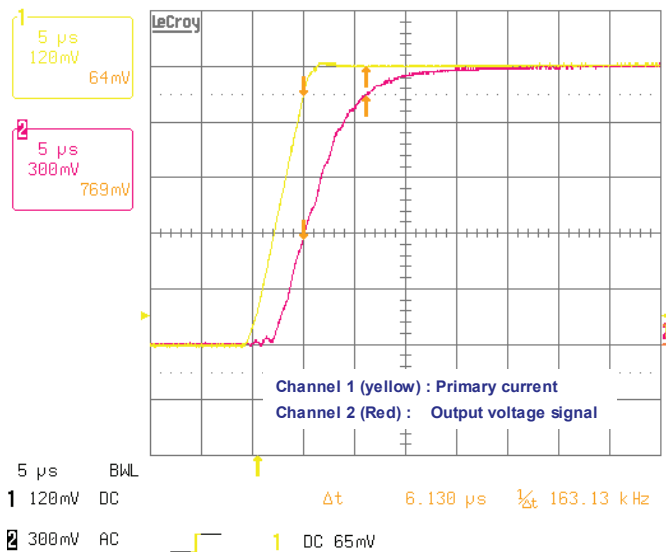

## HAH1DR 400-S/SP1

### Output noise voltage:

The output voltage noise is the result of the noise floor of the Hall elements and the linear amplifier.

### Magnetic offset:

The magnetic offset is the consequence of an over-current on the primary side. It's defined after an excursion of  $I_{PN}$ .

### Linearity:

The maximum positive or negative discrepancy with a reference straight line  $V_{out} = f(I_P)$ .

Unit: linearity (%) expressed with full scale of  $I_{PN}$ .

### Response time (delay time) $t_r$ :

The time between the primary current signal ( $I_{PN}$ ) and the output signal reach at 90 % of its final value.

### Sensitivity:

The Transducer's sensitivity  $G$  is the slope of the straight line

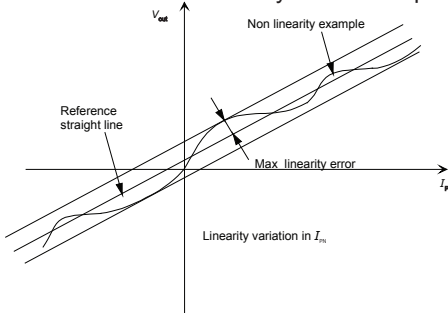

$V_{out} = f(I_P)$ , it must establish the relation:  
 $V_{out}(I_P) = U_C/5 (G \cdot I_P + V_o)$

### Offset with temperature:

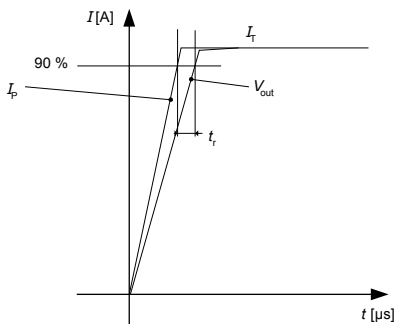

The error of the offset in the operating temperature is the variation of the offset in the temperature considered with the initial offset at 25 °C.

The offset variation  $I_{OT}$  is a maximum variation the offset in the temperature range:

$$I_{OT} = I_{OE \max} - I_{OE \min}$$

The Offset drift  $TCI_{OEAV}$  is the  $I_{OT}$  value divided by the temperature range.

### Sensitivity with temperature:

The error of the sensitivity in the operating temperature is the relative variation of sensitivity with the temperature considered with the initial offset at 25 °C.

The sensitivity variation  $G_T$  is the maximum variation (in ppm or %) of the sensitivity in the temperature range:

$$G_T = (\text{Sensitivity max} - \text{Sensitivity min}) / \text{Sensitivity at } 25 \text{ } ^\circ\text{C}$$

The sensitivity drift  $TCG_{AV}$  is the  $G_T$  value divided by the temperature range. Deeper and detailed info available is our LEM technical sales offices ([www.lem.com](http://www.lem.com)).

### Offset voltage @ $I_p = 0$ A:

The offset voltage is the output voltage when the primary current is zero. The ideal value of  $V_o$  is  $U_C/2$  at  $U_C = 5$  V. So, the difference of  $V_o - U_C/2$  is called the total offset voltage error. This offset error can be attributed to the electrical offset (due to the resolution of the ASIC quiescent voltage trimming), the magnetic offset, the thermal drift and the thermal hysteresis. Deeper and detailed info available is our LEM technical sales offices ([www.lem.com](http://www.lem.com)).

### Environmental test specifications:

Name	Standard	Conditions
Damp heat, steady state	JESD22-A101	85 °C - 85 °C / 1000 h
Isolation resistance	ISO 16750-2 § 4.10	500 V/1min
Temperature humidity cycle test	ISO 16750-4	- 10 + 85 °C 10 days
Isolation test	IEC 60664-1	2 kV / 50 Hz / 1min
<b>Mechanical tests</b>		
Vibration test (random)	IEC 60068-2-64 ISO 16750-3 & 4.1.2.5 (2007)	20 ... 2000 Hz Random rms (11g rms) 8 h / axis
Terminal strength test	According to LEM	
Thermal shocks	IEC 60068-2-14 Na	- 40 + 125 °C 300 cycles
Free fall	ISO 16750-3 § 4.3	1 m concrete ground
<b>EMC Test</b>		
Radiated electromagnetic immunity	Directive 2004/104/CE ISO 11452-2	30 V/m 20-2000 MHz
Bulk current injection immunity	Directive 2004/104/CE ISO 11452-4	1 - 400 MHz - 60 mA
Radiated radio frequency electromagnetic field immunity	IEC 61000-4-3	80 MHz to 1,000 MHz - 10 V/m
Electrostatic discharge immunity test	IEC 61000-4-2	Air discharge=2 kV